



# LATITUDE

ADVENTURE STARTS HERE

## Roof Tent User Guide

**YOU MUST READ THIS GUIDE BEFORE ATTEMPTING  
TO INSTALL OR USE YOUR ROOF TENT**





# Welcome, adventure starts here...

Thank you for purchasing a **Latitude** Roof Top Tent. We strive to provide the ultimate camping experience for every camper. Your top quality, durable **Latitude** Roof Top tent mounts directly to your roof rack or roof bars and can be fully setup in just a few moments.

**Latitude** Roof Tents are made with the most durable materials to withstand the most extreme conditions. High quality ripstop fabrics with a superior ventilate coating provide excellent water and wind protection.

To help you install your **Latitude** Roof Tent most of the components have been fully assembled at our factory, with the exception of attaching the mounting rails and the ladder to the base of the tent. Installation is composed of unpacking, attaching mounting rails to the base of the tent, attaching the ladder, attaching the tent cover, and then mounting your **Latitude** Roof Tent onto your roof rack or roof bars. All of the tools and hardware required for installation are included.

Should you have any questions, please email:  
[info@latitudetents.com](mailto:info@latitudetents.com)

FOR A DETAILED INSTRUCTIONAL VIDEO ON HOW TO INSTALL YOUR  
ROOF TOP TENT VISIT: [WWW.LATITUDETENTS.COM/INSTALIATION](http://WWW.LATITUDETENTS.COM/INSTALIATION)



## **WARNING**

Improper installation or use of your tent may result in serious injury or death. Follow these installation instructions carefully to ensure proper installation on your vehicle and safe use of your tent. Please check with your vehicle manufacturer for specified loading capacity of your roof rack.



## Contents

|   |         |
|---|---------|
| Getting Started                                   | 3       |
| Hardware Identification Chart                     | 4       |
| Tent Orientation On Your Vehicle                  | 5       |
| Tent Assembly                                     | 6       |
| - Attaching Mounting Channels                     | 7       |
| - Installing the Ladder                           | 8       |
| - Installing Travel Cover                         | 8       |
| Vehicle Installation - Attaching to the roof rack | 9       |
| Tent Set Up                                       | 10 - 11 |
| - Setting Up the Tent                             | 12      |
| - Setting Up the Annex                            | 12      |
| - Installing the Boot Bags                        | 13      |
| Storage and Handling                              | 14      |
| Warranty  | 15      |
| Hints and Tips                                    | 16      |
| Notes   | 17      |
| Contact Details                                   | 18      |



## Getting Started

1. Start by opening one end of the box. **BE CAREFUL NOT TO CUT THE TENT FABRIC!** Fold back the box flaps and flip the box so the open side is pointing down. You should be able to slide the box straight up and off the tent.
2. Lay the tent so the side with the eight holes in the base are facing up.
3. Locate the mounting rails and set aside.
4. Undo the 2 buckles keeping the tent closed, unfold the tent, unzip one of the doors, and remove and set aside:
  - a. PVC cover (1)
  - b. Ladder (1)
  - c. Boot bags (1)
  - d. Hardware bag (1)
  - e. Canopy pole (1)











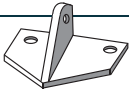





## What's in the Hardware Bag?

All of the tools you need to install your tent are included.

Clear a space to empty the hardware bag. Please check that all these items are inside:

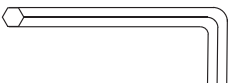
|   | Item.                                | Quantity/No. |
|---|--------------------------------------|--------------|
|    | Ladder Mounting Bracket              | 2            |
|    | 60 mm Stainless Steel Bolt           | 8            |
|    | 35 mm Stainless Steel Bolt           | 4            |
|    | 30mm Stainless Steel Bolt            | 4            |
|    | 20 mm Stainless Steel Bolt           | 2            |
|    | Stainless Steel Mount Plate          | 4            |
|    | Aluminium Slide Plate                | 8            |
|    | Stainless Steel washers (for Ladder) | 4            |
|   | 10 mm Nylock Nuts                    | 8            |
|  | 13 mm Nylock Nuts                    | 10           |
|  | Stainless Steel washers              | 8            |
|  | Combination Spanner 10 mm            |              |
|  | Combination Spanner 13 mm            | 1            |
|  | Allen Key - 4mm                      | 1            |
|   | Allen Key - 5mm                      | 1            |



## Tent Orientation On Your Vehicle

There are two mounting options for the orientation of your new **Latitude** Roof Top Tent. Either the tent will open so that the ladder extends off the back of the vehicle, “Rear Mounted,” or the ladder extends off the side of your vehicle, “Side Mounted.” Most of our customers choose to mount their tents with the ladder extending off the side of the vehicle, in the “Side Mounted” orientation.

Either orientation works for larger vehicles, however, most saloons, hatchbacks or smaller SUVs are better suited for the side mounted option.

### Side Mounted



#### Benefits for the side mounted orientation:

1. Allows for bicycle racks and other tow hitch/bar accessories to be installed without interfering with your tent operation.
2. Closed tent width will fit inside the roof dimensions of most cars and SUV's. i.e. the tent base will not extend beyond the roof line of your vehicle when closed.
3. Typically does not require cutting of the mounting rails.

### Rear Mounted



#### Benefits for the rear mounted orientation:

1. Fits into narrow camping spaces.
2. Trunk or tail gate area at the rear of your vehicle is accessible from inside the annex.



## Tent Assembly

### Attaching Mounting Rails

1. After removing the contents, close the tent so the channel mounting surface is facing upwards (the side with 8 holes in the centre area).
2. Take the mounting rails and align them with the pre drilled holes to coincide with the desired orientation.  
The inner 4 holes are for narrow roof bars under 80cm wide.

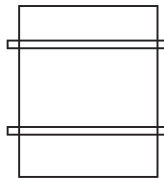

Rear Mounted

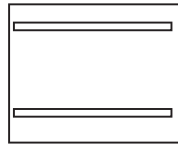

Side Mounted



3. Slide the 10 mm nylock nuts into the central channel on the mounting rails and align them with the holes.
4. Now take the 35 mm bolts with the large washers and slide them up through the holes from inside the tent and tighten.

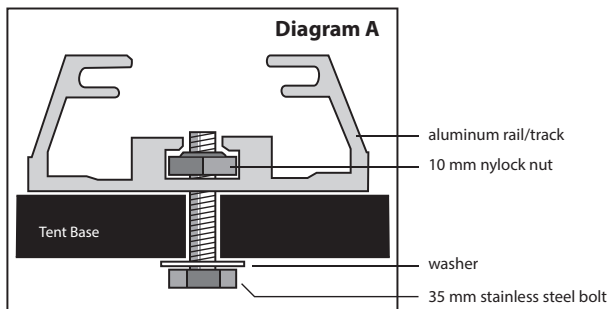





## Tent Assembly

### Installing the Ladder

1. Flip the tent over so the side with mounting channels is facing down.
2. Align the ladder brackets over the pre drilled holes at the edge of the bed/tent base.

3. Feed the 35mm bolts with washers from the inside of the tent and screw on the nylock nuts by reaching inside the tent.

**DO NOT TIGHTEN YET.**

4. Align the ladder with the brackets. Using the 20 mm bolts and remaining hardware (*see Diagram B*), attach the ladder and tighten.

Note: the order of the hardware should be:

Bolt - Washer - Bracket - Washer - Ladder - Nylock nut

5. Tighten the nuts attaching the ladder brackets to the tent frame.

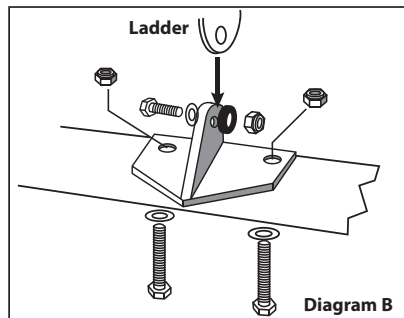



## Tent Assembly

### Installing Travel Cover

1. To attach the travel cover, first fasten the buckles on either side of the tent to compress and hold the canopy in place.



2. Slide the rounded fabric end of the cover into the rounded C-channel at the hinge side of the tent base. Make sure the cover is oriented so the exterior side of the cover faces up when you pull the cover over the tent. Then fold over.



3. Zip the travel cover to the base along the three edges, **taking care that the tent fabric does not become caught in the zipper.**



4. Secure the two long straps over the top of the travel cover and attach to the buckles.





## Vehicle Installing

### Attachment to the Roof Rack

1. Place the tent on top of your vehicle rack system, ensuring the mounting tracks are perpendicular to the bars they will mount to, and the tent is centered on the roof rack. Position the hinge so that the tent will open to the desired side.

2. Place 60 mm bolts into the slide plate. Slide the plate and bolt into the mounting tracks. Lift one side of the tent to position one set of bolts and channel sliders on the inside of the roof rack bar and an additional set on the opposite side. Repeat on all four corners.

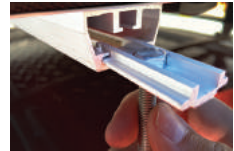

3. At each of the four corners where the rack bars and mounting tracks cross, use a steel mounting plate and nylock nut to secure the bolts on either side of the bar. Tighten all eight bolts securely with the included nuts and wrench. *Check all the mounting bolts and brackets periodically during use to ensure they are securely fastened to your rack system.*



4. After ensuring the tent is positioned correctly and all eight bolts are tightened securely, insert rubber end caps into the ends of the mounting tracks. This may require light taps from a hammer.

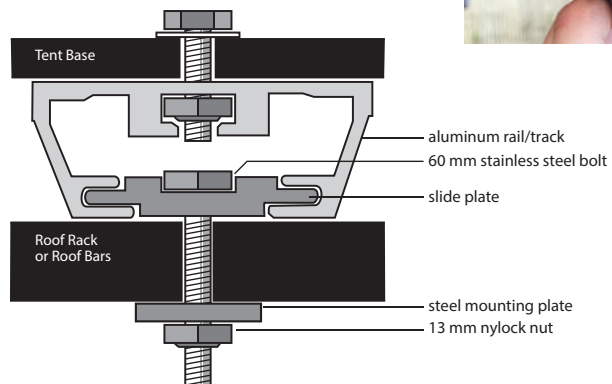
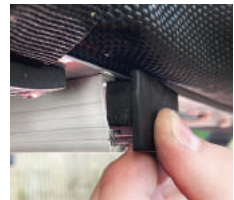



## Tent Set Up

### Setting Up the Tent

1. Release the straps over the travel cover. Unzip the cover and fold it back. You can remove it, roll it up, or let it hang off the side of your vehicle.



2. Undo the buckle straps keeping the tent closed.

3. Undo the velcro strap, securing the ladder and fully extend it until the locking pins in each section engage.



4. Use the ladder as leverage to open the tent by pulling straight back until the ladder rests firmly on the ground. Assure all the steps on the telescopic ladder are locked. The tent base should be level and the ladder should form a 60° angle with the ground.

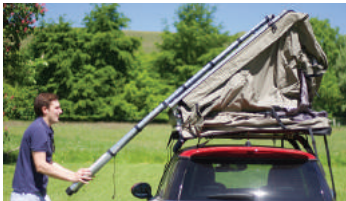



5. To adjust the height, start with the top section, pressing the two buttons on the ladder rung to release the locking levers. Slide the ladder up so that it recedes into the top rung. Repeat for each section until the ladder is the desired height.

Be sure that the remaining sections of the ladder are fully locked.

6. Applying the ladder canopy support pole.

Firstly, begin by pushing it into the fabric corners of the ladder canopy. Now look at the corners of the frame. There are hinged brackets that you will insert the end of the awning support pole into to secure it.



7. You can now locate the window awning poles. These are found in a pocket below the window at the opposite end to the ladder. There are 2 holes drilled into the frame to insert the end of the window poles. These can be accessed through slits in the tent skirt. Insert the straight end into the frame at about 45° angle, bend it back and insert the curved end through the eyelet in the window awning.

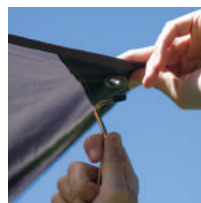

***THATS IT! You're ready to camp.  
Welcome, the adventure starts here!***



## Tent Set Up

### Setting Up the Ground Floor Extension (if included)

1. To start, you'll need to remove the travel cover if you have not already. Do so by sliding it to one side and out of the channel in the frame.
2. Take the fabric walls of the annex and locate the corded edge. Insert this edge into the same channel you just removed the travel cover from and feed it through.

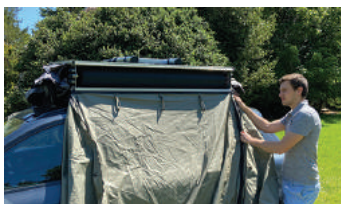

3. Use the ladder as leverage to open the tent by pulling straight back. Position the ladder so it is encompassed by the annex walls. Zip the remaining three sides of the annex onto the base of the tent.

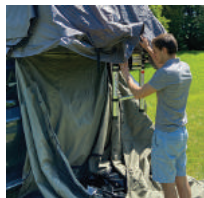

4. Applying the ladder awning support pole, see page 11 - point 6.
5. Stake out at all four corners to maximise interior space and secure the annex. Now you can lower the ladder back down and your annex is ready to use.





## Tent Set Up

### Installing the Boot Bags

Install the boot bags by sliding the fabric edge into the frame on the side where the ladder is mounted.





## Storage and Handling

### **Clean and dry your tent after each camping trip:**

*Every time that you return from camping you should clean and dry your tent. Also, wash the mattress and cover once in a while (only hang dry).*

1. Open the tent fully and brush / vacuum inside.
2. Clean the fabric as needed using a mild detergent, warm water, and a soft to medium brush.
3. Rinse fabric of all detergent prior to drying.
4. Dry tent in the sun with all windows open. The tent must be completely dry before storage, or mildew and mold may occur. This is especially necessary after camping in rain or wet conditions.
5. Using a small brush, remove dirt from zippers. Use a silicon spray to keep zippers lubricated.
6. Wash mattress pad and hang to dry.





## Warranty

### WHAT IS COVERED

**Latitude Tents Limited**, warrants to the original purchaser that its products are free from defects in material and workmanship, for the term described, except as qualified below. The life of the product is determined from the date of purchase until such time as the product is no longer serviceable due to normal wear and tear.

### WHAT IS NOT COVERED

**Latitude Tents Limited**, shall not be responsible for the natural breakdown of materials that occurs inevitably with extended use (e.g., Ultra Violet (UV) light damage on tents, exhausted zippers), or defects caused by accident, abuse, alteration, animal attack, storm damage, misuse or improper care.

### WHAT LATITUDE TENTS LIMITED WILL DO

If after inspection we find that a product failed due to a manufacturing or material defect, we will repair or replace the product, at our option, without charge.

### HOW TO OBTAIN WARRANTY SERVICE

Return the product, freight prepaid, to the Latitude Tents Dealer from whom it was purchased; or, contact **Latitude Tents Limited** via email: [info@latitudetents.com](mailto:info@latitudetents.com). Collect shipments or shipments without return authorization cannot be accepted.

### REPAIRS

If your tent needs service or repair due to normal wear and tear, animal attack, accident or some other reason that is not covered under the warranty, we will provide the necessary service for a reasonable charge, plus shipping and handling. We require that products accepted for any repair be properly cleaned according to our recommended care instructions. Please send your product or component that requires repair (e.g., tent fly), postage prepaid, along with a description of what needs attention. For service and repairs, please contact **Latitude Tents Limited** via email: [info@latitudetents.com](mailto:info@latitudetents.com).

### WARRANTY TERM

Limited 2 year warranty applies to all tent components including base, aluminum poles, ladder, fabric and seams.



## Hints and tips

### **1. Those fabric cords inside the roof tent?**

The elastic cords that come inside the tent, they're there to help when folding the tent up. They pull the fabric inwards so there's less to pack in before installing the travel cover. Keep them in one of the interior pockets whilst your in the tent, then refit them before you pack it up!

### **2. Roll up window awnings.**

The exterior window awnings can also be rolled up just like all the door & window covers. This helps get more light in and upward views from inside the tent.

### **3. Fold back Rainfly.**

The rainfly on top of the tent can easily be folded back for completely unobstructed views from the skylight. Or you can completely remove it altogether in a couple of minutes, and it's just as easy to reinstall.

### **4. Run chargers through the velcro strap.**

The little velcro flaps around the hinge area allow you to run power cables from inside your car to inside your tent! Late-night movies in the comfort of your Latitude roof tent, check.

### **5. Use provided guy lines to keep the tent taut and prevent flapping.**

The two guylines and tent pegs are there to keep the tent taut and prevent flapping in the wind. Hook them on to the edge of the ladder canopy and into the ground.

**6. Check out 'Anti Condensation Mat'** to prevent condensation build up around mattress. They fit beneath the mattress to allow air to move freely and prevent moisture build-up.

### **7. FOLLOW US ON INSTAGRAM! @latitude\_tents**

We love to see your adventures and what the #latitudefamily gets up to.



LATITUDE

## Notes

---

---

---

---

---

---

---

---

---

---

---

---

---

---

---

---

---

---

---

---

---

---

---

**contact details:**  
[www.latitudetents.com](http://www.latitudetents.com)  
Tel: 07377 456 037





**LATITUDE**  
[www.latitudetents.com](http://www.latitudetents.com)

